

EFM-45™

Modular Iris Recognition System with LCD touchscreen
Based on innovative EF-45NC iris and face recognition system



APPLICATION

For customized integration into kiosks, ATM's, and similar automated, self-service applications.

Product Description

The EFM-45 is the modular version of CMITech's next generation EF-45 dual iris imaging system. It is intended for specialized solution integrators to incorporate high accuracy iris recognition biometrics into a kiosk or similar self-service terminal.

This system's operation is identical to CMITech's EF-45NC iris recognition terminal product, which provides unprecedented subject ease of use through a highly innovative and intuitive user positioning approach.

New to the EFM-45 is a central 1.45" touch LCD, which assists the user in intuitive positioning, making capture of the iris and face images faster and easier. This independent user interface allows the integrator to position the units without regard to the kiosk's own display panel. It provides the same positioning feedback cues and instructions as in the EF-45 system including sound.

Subjects will view their own face in the LCD to position themselves correctly. Each subject will intuitively and naturally move to the correct position by simply centering and sizing their face image to the positioning box within the display. In addition, this box turns green to indicate that the subject is within the proper distance range of 35 to 45cm, after which the iris biometrics images are automatically captured.

The EFM-45 can be used with a desktop cradle to allow it to be utilized as an enrollment device for an EF-45NC installation.

The EFM-45 is an embedded system that includes its own ARM mainboard to manage all iris and face imaging processes. The communication options to the host system are TCP/IP via an Ethernet connection or a USB connection.

User Interface

The user interface will be shown at the LCD screen display.

Position face within guide box in display



Move Forward
Blue for too far away



Good
Blue for too far away



Move Backward
Blue for too far away

Position face within guide box in display



Success
Authentication success or capture of iris and face is completed.

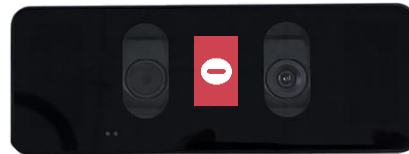

Failed or Denied
Authentication failed or denied. Or capture of iris and face is failed.



Warning!
System warning message displayed.

Find the setup parameter and change



Enter the Setup
Touch the center of LCD screen

Menu: UI, Volume, Detection, Language, IP address, Mac, Camera and Firmware version.



Change Setting
Touch the arrow icon on top and bottom

In case of changed the language option then please touch the center of screen so that reboot the system.



Return to Launcher
Leave without touch for 10 seconds.

The screen will restart capture mode.

System Interface

Cable and data connections

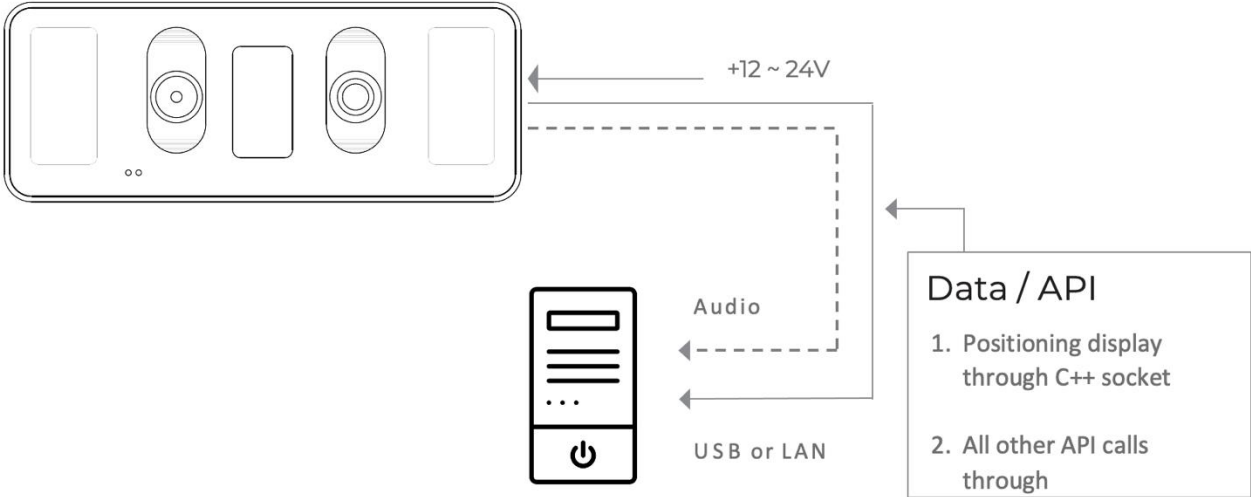

System Diagram

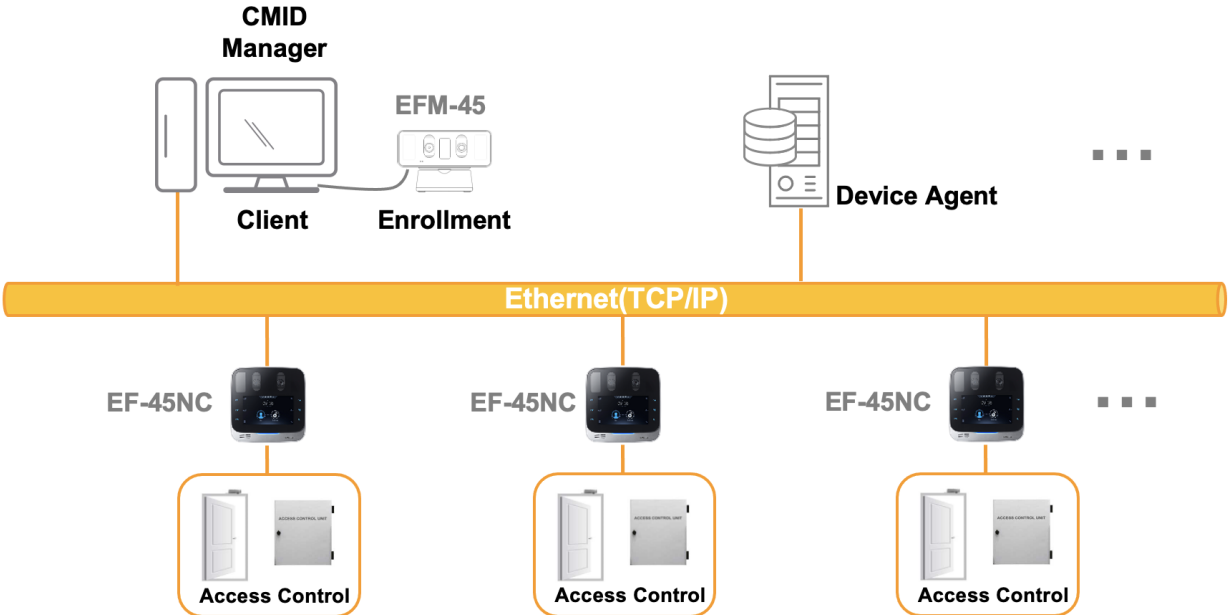

Dimensions

Dimensions of 150 x 58 x 56mm without a desktop cradle.

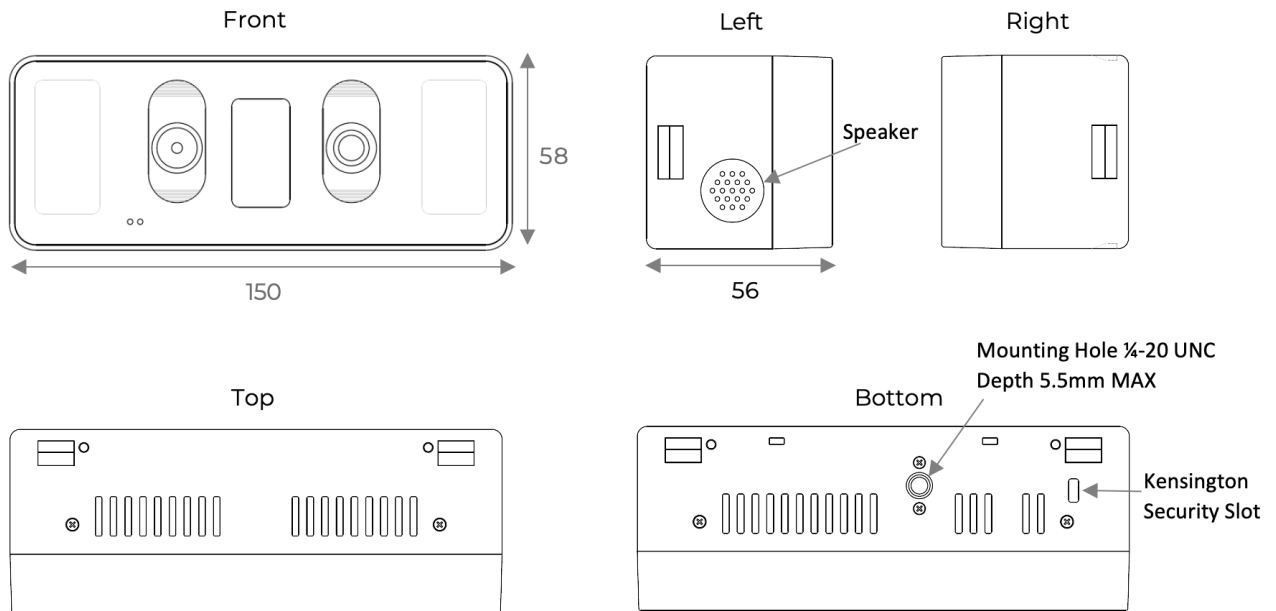

Connectors

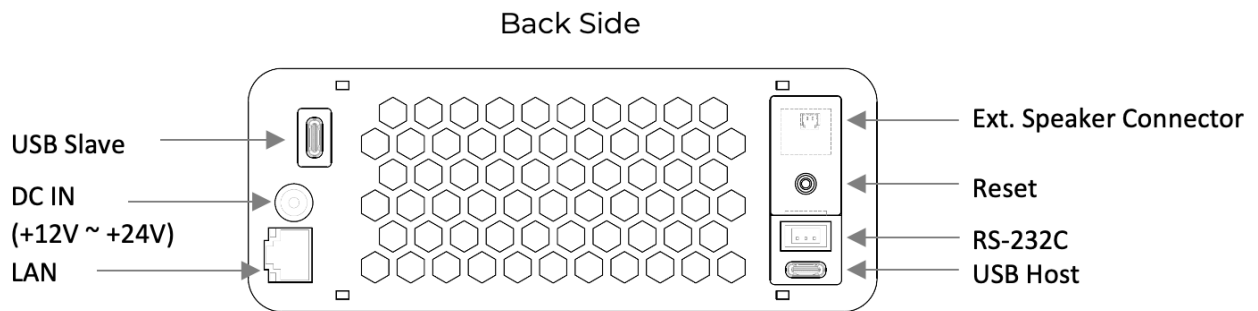

Desktop Installation

The desktop use of the cradle is an option.

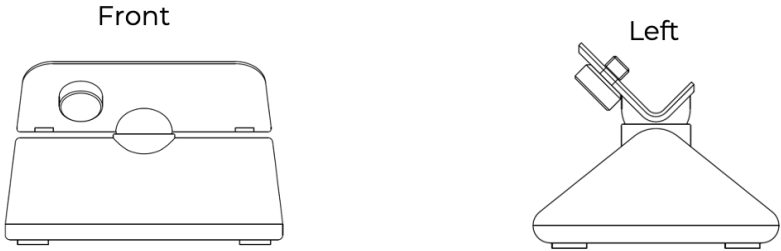

Mounting Installation Overview

The EFM-45 is designed for in-dash amount installation basically. Depending on the installation environment user should use or customize a bracket as recommend.

Type A : Top/Bottom side mount using a bracket

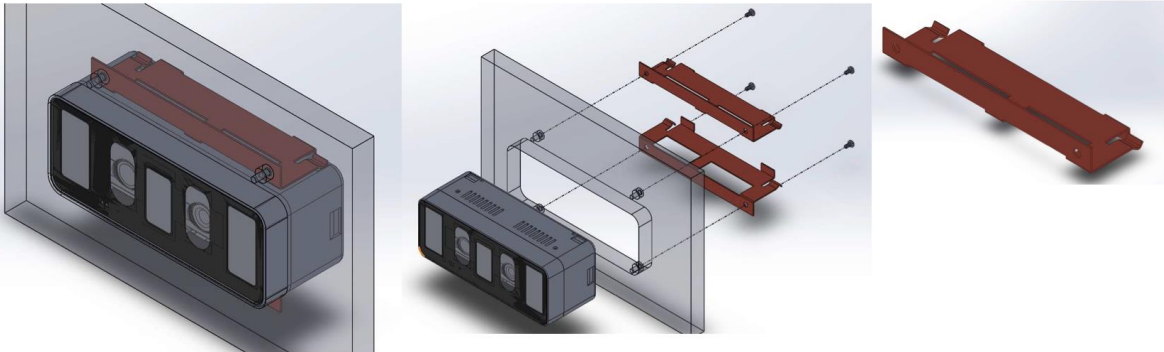

Type B : Side mount using a bracket

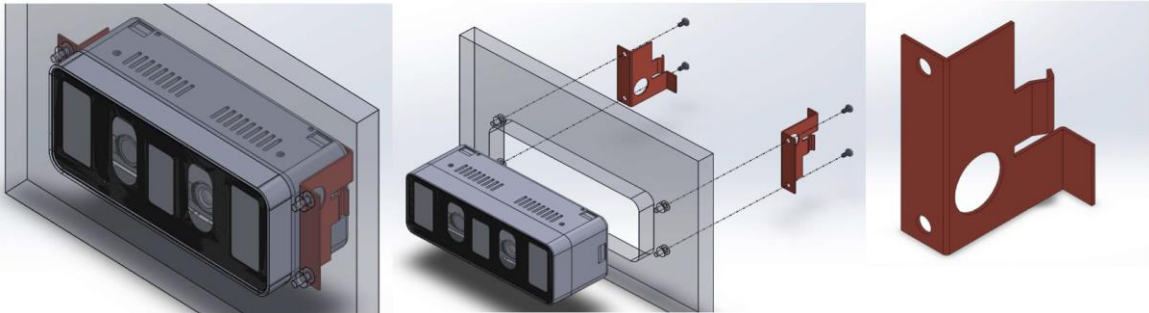

Type C : Auto clamp bracket top and bottom

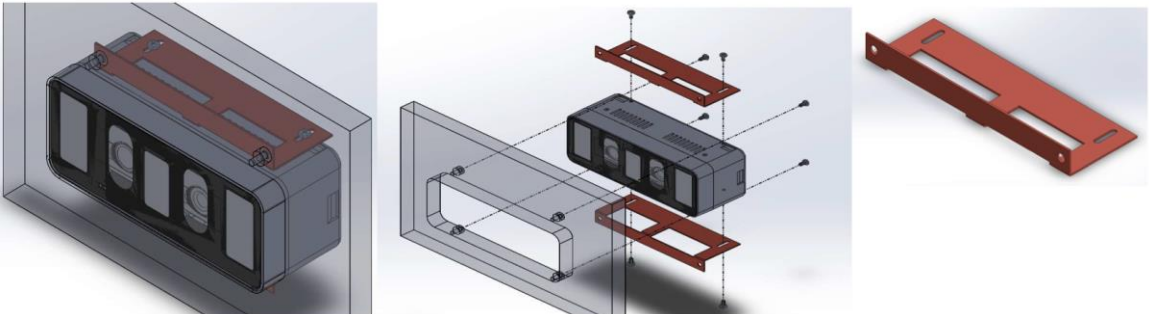

Technical Specifications

Embedded CPU	ARM Cortex A55 quad-core processor
Memory	DRAM 2GB, FLASH 8GB
Iris on-board algorithm	Standard Delta ID
Face on-board algorithm	Please contact CMITech for details
SDK configurations	High level SDK is RESTful type that includes host side application for LAN or USB connection to EFM-45 resident services layer. Requires Windows API development to EFM-45 host side application. Reference code included.
Host side compatibility	Windows C# (.NET), Windows C++, Linux C++ on x86 platform. Please contact CMITech for Java or Android support.
Dimensions	150mm x 58mm x 56mm
On-board data storage	Up to 100,000 iris template pairs (useful for 1:N authentication mode) with match speed of under 0.5 seconds.
Iris image output	Meets ISO 29794-6 and 19794-6 2011 standards
Iris image pixel resolution	640 x 480 pixels, 8 bit depth. Output format .bmp standard
Standard operation iris imaging distance	30 to 45 cm range (15cm depth of capture) in enrollment mode
Simplest of user instructions	<p>Very simple and repeatable subject instructions:</p> <ul style="list-style-type: none"> • Position face within guide box in display • Move toward the system to size head to box • Once within range, the box bar will turn green to indicate proper positioning <p>Capture is automatic once subject is in proper position and real time image quality metrics parameters are met.</p>
Speed of iris image capture	Typically about 0.5 second from time subject's eyes are placed within proper capture volume.
IR illumination for iris imaging	Dual wavelength near infrared (NIR) LEDs to conform to ISO best practices for iris imaging.
Face image capture	Standard 24-bit color (for reference image)
Auto tilt	Internal: +25 to -20 degree up/down tilt
LCD	1.45" (172x320 pixels) with touch screen
Sound	Internal speaker embedded with external speaker connector
I/O	USB 2.0 host (Type-A), USB-2.0 Slave (Type-A), RS-232C, Factory Reset
Voltage	12 to 24V, 24W
Power Adaptor	Optional
Kensington Lock	Yes
Tripod mount thread	¼ / 20 UNC (standard consumer tripod)
Desktop cradle	Optional
Operating temperature range	-20 to 50°C
Humidity	10 to 90% RH, non-condensing
Illuminator eye safety standard and certification	IEC 62471
Other certifications	CE, FCC, UKCA, KC

Contact Information

Please Contact CMITech or your representative for more information about the NovaFace product, CMIRIS Software Development Kits (SDK) and other supporting software.

CMITech Company, Ltd.

4th Floor, #417 - 419, 136 LS-ro,
Dongan-gu, Anyang-si,
Gyeonggi-do, 14118, Republic of Korea

Tel: +82.70.8633.8277

Fax: +82.31.624.4490

Contact: sales@cmi-tech.com

CMITech America, Inc.

2033 Gateway Place, Suite 500
San Jose, CA 95110 USA

Tel: (1) 408 573 6930

Copyright 2022 CMITech Company, Ltd.—All Rights Reserved.

CMITech Company, Ltd. reserves the right to make changes to specifications and features shown herein, or discontinue the product described at any time without notice or obligation.